

# Work and Energy

THIS YEAR I HAVE  
6 WEEKS OF VACATION,  
BUT 52 WEEKS  
OF WORK!!



# Work and Energy

Force = push or pull

Work = force\*distance (//)

Sample 1: How much work is done lifting a 5 N weight 3m vertically?

Sample 2: How much work is done by a man who is 1.8 m tall pushing with a force of 20 N on a stone wall?

Sample 3: How much work is done by a student who carries his computer which has a mass of 1.3 kilograms a horizontal distance of 5 meters?

Sample 4: How much work does the student do if he carries the computer up a flight of stairs which has a vertical rise of 7.2 m ?

## Kinetic Energy:

The ability to do work which an object has because of its motion.

**Equal to** the amount of work expended in accelerating the object from rest up to its speed.

$$KE = \frac{1}{2} mv^2$$

Sample 1: What is the kinetic energy of a 2.1 kilogram mass moving at 5.2 m/s?

Sample 2 A bullet having a mass of 8.2 grams is moving at 100 m/s.

(A) Calculate its kinetic energy.

(B) If the barrel of the gun was 0.5 m long, calculate the average force exerted by the expanding gasses.

Page 261.

A 105 g hockey puck is sliding across the ice. A player exerts a constant 4.5 N force over a distance of 0.15 m. If the force was in the direction the puck was originally moving, how much did the kinetic energy of the puck change?

Page 261

A rock climber wears a 7.5 kg backpack while scaling a cliff. After 30. minutes, the climber is 8.2 m above the starting point.

(A) How much work does the climber do on the backpack?

(B) If the climber had a mass of 75 kilograms, how much work did he do lifting himself and the backpack?

Two students climb vertical ropes in the gym. Each of them has a mass of 70 kilograms. Jimmy climbs 10 m in 8 seconds. Kasey climbs 10 m in 18 seconds.

(A) Who did more work?

(B) Who was able to work faster?

$$\text{Power} = \frac{\text{Work}}{\text{Time}}$$

Two students climb vertical ropes in the gym. Each of them has a mass of 70 kilograms. Jimmy climbs 10 m in 8 seconds. Kasey climbs 10 m in 18 seconds.

How much POWER does each of them develop?

Page 265

#18. An elevator lifts a total mass of  $1.1 \times 10^3$  kg a distance of 40 m in 12.5 s. How much power does the elevator generate?

Page 265 #18

A 0.18 kg ball falls 2.5 m. How much work does the force of gravity do on the ball?

## **Potential Energy**

**The ability to do work which a system has because of its condition or the relative position of its parts.**

**Equal to the amount of work done setting up the conditions.**

**Example:**

**How much work is done by a man having a mass of 72 kilograms who climbs a ladder a vertical distance of 4.0 meters?**

Page 278 # 52

The third floor of a house is 8 m above street level. How much work is needed to move a 150 kg refrigerator to the third floor?

Page 278 # 54

After scoring a touchdown, a 84 kg wide receiver celebrates by leaping 1.2 m off the ground. How much work was done by the wide receiver in the celebration?

Page 279 # 57

A cyclist exerts a force of 15 N as he rides a bike 215 m in 30 seconds. How much work did he do?

Page 278 # 61

Shani is pushing a lawn mower with a force of  $88\text{ N}$  along a handle that makes an angle of  $41$  degrees with the horizontal. How much work does he do moving the lawn mower  $1.2\text{ km}$  to mow the yard?

**Conservation of energy:  
In a closed, isolated system energy is conserved. That is to say it can neither be created nor destroyed; but it can be changed from one form to another.**

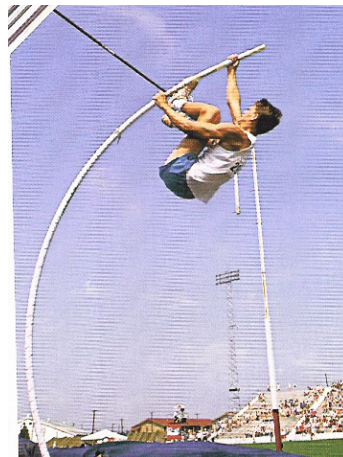

Suppose a 72 kilogram boy is at rest at the top of a ski slope which is 20 meters high at a physics resort. He begins to slide (naturally there is no friction). How fast will he be going after he has lost 35 meters of altitude?

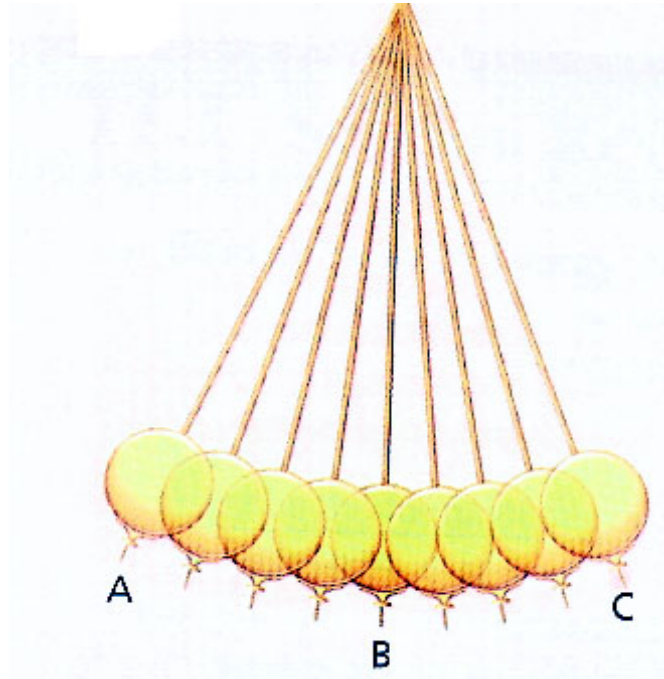

A bowling-ball is set up as a simple pendulum. When it is at the extreme end of its swing it is  $.25$  m above the lowest point of its swing. How fast will it be moving when it passes its lowest point?

Two boys one of mass 70 kilograms and the other of mass 80 kilograms swing from a rope across a canyon. Assuming they start at the same height, what can you say about their relative velocities as they pass through the bottom of the arc?

Base your answers to questions 81 through 85 on the following information and diagram.

A 2.0-kilogram mass is placed on a frictionless track at point A and released from rest. (Assume that the gravitational potential energy of the system is zero at point E.)

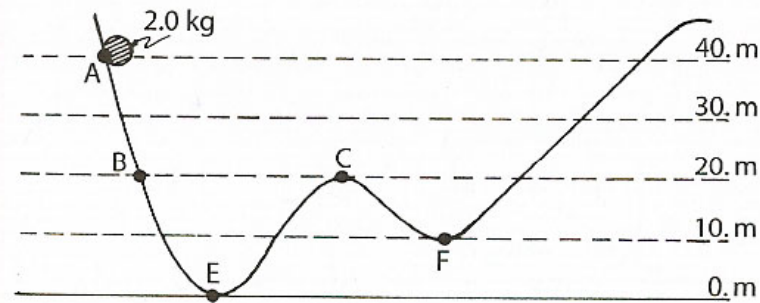

81. Determine the gravitational potential energy of the system at point A.
82. Compared to the kinetic energy of the mass at point B, the kinetic energy of the mass at point E is  
(1) the same (2) twice as great (3) half as great  
(4) four times as great
83. On the diagram, mark an X on the track to indicate the maximum height the mass will reach above point E after the object has passed through point E.
84. If the mass was released from rest at point B, its speed at point C would be (1) 0 m/s (2) 0.50 m/s  
(3) 10. m/s (4) 14 m/s
85. Compared to the total mechanical energy of the system at point A, the total mechanical energy of the system at point F is (1) less (2) more (3) the same

Page 279 # 66

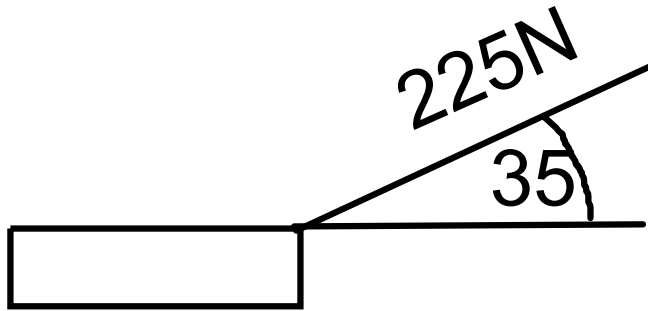

Diego pulls a 4.5 kg sled across a level snow with a force of 225 N on a rope that is 35 degrees above the horizontal as shown. The sled moves 65 m. How much work was done?

## Page 279 # 70

Maricruz slides a 60 kg crate up an inclined ramp that is 2.0 m long and attached to a platform 1.0 m above floor level. A 400 N force, parallel to the ramp is needed to slide the crate up the ramp at a constant speed.

(a) How much work does Maricruz do in sliding the crate up the ramp?

(b) How much work would be done if he simply lifted the crate straight up from the floor to the platform?

